

ST 10 B/L 10 and ST 20 B/L 20

Installation and Operation Instruction Manual



Solar Charging
Controller

10A / 20A IP65

Table of Contents

1. Solar Charge Controller with Fuzzy-Logic	2
a. Overall functions of the controller	2
b. Control and regulative Functions	2
c. Options	2
2. Configuration	4
3. Installation	5
4. Operation	7
a. Putting system in operation	7
b. Status Displays	7
c. Maintenance	7
5. Errors	7
6. Safety Precautions, Nonliability, Guarantee	7
7. Technical Data	9
a. Block Diagram	10
b. Groups of solarpanels	11
c. Information display	12
d. State of Charge display	12

1. Solar Charge Controller with Fuzzy-Logic

a. Overall functions of the controller

The controller is for use in PV-systems with battery storage in the field of leisure as well as in the living area, in smaller industrial systems.

The charge controller surveys the state of charge of the battery, controls the charging process as well as the switching on and off of the users. Thus the battery can be used

b. Control and regulative Functions

• SOC Determination

By means of a new special algorithm the controller is able to "learn" the characteristics curve of the accumulator. After this phase of learning the state of charge (SOC) is displayed with medium accuracy of approx. 10%. This state of charge is basis of most control and regulating functions.

• Overcharge Protection

Frequent overcharging harms your battery. The charging process and the overcharge protection are therefore controlled by a new type of hybrid circuit with pulse width modulation in order to ensure a gentle charging of the battery.

• Voltage Recognition

By using a special measuring procedure accu sensor wires are no longer necessary. A voltage drop is compensated.

• Cycle Charge (Lead/Gel)

When the SOC falls below 70% the final charge voltage is raised for 1 hour.

• Equalization Charge (only Lead)

When the SOC falls below 40% the equalization charging is activated. During this process the final charge voltage is raised for 1 hour, the electrolytes are mixed through and

c. Options

• Temperature-Tracking of the final Charge Voltage

The ideal final charge voltage of lead accumulators falls with increasing battery temperature. A fixed final charge voltage leads to uncontrolled gassing by constant overcharging when higher battery temperatures are reached. The temperature tracking lowers the final charge voltage at high temperatures and raises the final charge voltage

optimally and its service life is prolonged considerably.

The controllers are for use with lead accumulators with liquid electrolyte and can be adapted for use with other electrolytes. The controller can be used with all solar modules up to the maximum connection value of the module.

thus the service life of the battery is prolonged.

• Monthly Charging

Depending on gel or lead accu, the corresponding increase of the final charge voltage is maintained for one hour.

• Displays

The operator is informed by two LED's about the operation status of your system. LED1 (the Info-LED) is for the controllers status, LED2 (SOC-LED) is for the battery.

• Overdischarge Protection

Overdischarging leads to a capacity loss because of sulfation. The overdischarge protection switches off the users. When the SOC is higher than 50% they are automatically reconnected.

• Additional protective functions

The controller itself as well as the users are protected from overload by an electronic overcurrent disconnect. Higher initial velocity currents, as occur when engines are operated, are allowed. AtonIC protects the controller from over and undervoltage and too high temperature. Furthermore a fuse melt is pre-switched as final instance.

at low temperatures. The temperature tracking with an external sensor is active during cycle and equalization charging. As a protective function of the users the final charge voltage is never increased over 15V (e.g. equalization charge at low temperatures).

• LCD-Display

The most important system parameters are displayed on the optional LCD-display.

During normal operation the display changes after 3 sec. to the next parameter. In the case of error it is shown what kind of error.

- Normal operation :

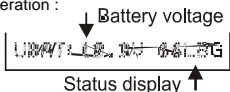

The display shows the terminal voltage of the battery. The status display consists of 5 symbols. The first two symbols are internal control parameters. The first letter shows if the load disconnect is voltage „S“ or SOC „L“ controlled. The second letter shows if a lead acid „B“ or a gel accu „G“ is adapted. The last letter indicates if the controller is doing normal „N“, cycle „G“ or equalization „A“ charge at the next cycle.

- Display of SOC (State of Charge):

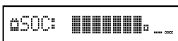

The SOC of the battery can be seen on a bar display. Each big bar is for 10% SOC. The small bar is for additional 5% SOC. The example above is 75% SOC

- Display of Charging Current :



The bar display for load current shows the percentage of the nominal module current (this value is dependent from the power class of the controller) flow into the accumulator. The evaluation is the same as for SOC.

Despite full sun infall no bar can be displayed when the accu is full and the module current is short circuited.

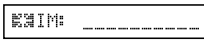

By an inverted sun symbol (see above) it is additionally displayed when no charge current

flows at all (e.g. at night).

- Display of Load current:



The bar display for load current shows how many percent of the nominal load current (dependent from the power class of the controller) flow into the users.

- Display of Errors :

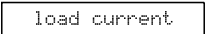

In the case of an fault it is clearly displayed which error causes this fault.

There are following error displays :

- load current
- module current
- over voltage
- low voltage
- over temperature

The optional displays are attached in the casings. The connection cables of the display are plugged and can be removed for assemblage.

- **Option manual load disconnect**

Every controller offers the possibility to determine when the load is disconnected.

For this purpose, a simple push-button has to be connected at the grey terminal of the external temperature sensor. By pressing and holding the button the function of the overdischarge protection is changed.

The Info-LED serves as a visual control unit

Info - LED red	=	LOAD OFF
Info - LED green	=	LOAD ON
Info - LED yellow	=	AUTO

Important: The resistor connected at the small grey terminal (value 33K Ω) may not be removed. The switch has to be parallel with the resistor.

- **Option high temperatures and humidity**

The charge controllers are available in a special make suitable for high temperatures and humidity. This option causes a reduction of the admissible currents.

2. Configuration

The solar charge controller adapts automatically to the system's voltage (12/24V) when it is installed.

The controller is in a state that it can be used for most cases without changes. It is only necessary to adapt the controller in following cases :

- use of a gel accu.
- activation of nightlight function.
- direct connection of a main user at the battery

Adaption is made by means of jumpers which can connect two neighboring contact needles.

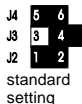

The controller is supplied with activated equalization charge i.e. it is ideal for batteries with liquid electrolyte. With other batteries the equalization charge is deactivated. Please see the regulations of the manufacturer.

• Selection of accumulator

Lead : Either remove jumper J3 or place it for storage on pin 4 (standard).

Gel : For the use of a gel accumulator jumper J3 has to be placed on contact needles 3 + 4.

• Direct Connection with a Battery

When the battery is connected with other charger or a grid connect inverter the SOC display does not work. In this case the controller can be adjusted to voltage orientated regulation. All functions are released by different voltage levels.

This also applies for the SOC-display.

LED	voltage	LCD
red	10.8 V	0 bars
yellow	12.0 V	5 bars
green	132	10 bars

In this status the SOC-LED works as a color

Multimeter.

For this purpose jumper J2 has to be removed from contact needles 1 + 2.

Keep your jumpers safe so that the controller can again be reset to standard! Possibility for storing, place jumper only on Pin 2.

Users which shall not be disconnected by the load disconnect (e. g. position lights at boats) may be connected directly with the battery! Higher danger of overdischarge which is no longer controlled by the system controller!

• Nightlight function

When the controller is used with lighting systems the so-called nightlight function can be programmed. When this function is activated all users are connected at night and disconnected at daytime. The overdischarge protection remains activated.

In order to activate the nightlight function, jumper J4 on contact needle 5 + 6 has to be removed.

Overview:

Jumper	closed	open
J2: 1-2	SOC	voltage
J3: 3-4	gel	lead
J4: 5-6	-	nightlight

Example

J4 closed: without nightlight function; J3 open: Lead accu; J2 open: direct connection to accu.



When you are not sure that you are able to configure the controller yourself, please contact your dealer. There is no liability for any damages caused by incorrect adjusted controllers!

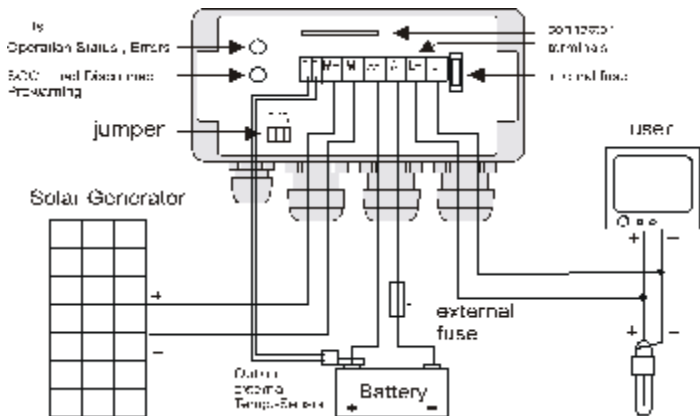

Illustration 1: Circuit diagram

3. Installation

Place of Installation

Do not install or operate PV components in rooms where easily flammable gases can develop! Explosive gases can develop near the battery. Therefore avoid any sparking and see that the battery room is well ventilated. Follow the regulations for batteries!

Also pay attention to:

- DIN VDE 0510 part 2, sect. 7 (explosion danger), 8 (dangers by electrolyte), 9 (place of installation); National Electric Code, art.690.

Attachment

Ensure the following precautions:

- Install with cable screwing downwards.
- Keep a minimum safety distance of 100 mm to devices above and below the controller.

Proper attachment:

Hole diameter at controller: 4,3 mm.

Fixing at non-metallic walls in vehicles: Avoid

Preparation of wiring

Only use cables with an appropriate diameter for the power class of the controller. This means at least a cable diameter of 4 mm² for 10A-current and 6 mm² for 20A.

Also check if

Choose the place of installation according to following criteria:

- Shelter from direct weather conditions.
- Avoid direct sun light and heating caused by nearby devices.
- Ensure air circulation around the casing
- Installation place as near as possible at the battery (safety distance at least 30cm).
- See that there is no humidity or dirt.

tearing out of screw heads by using a piece of tin in the size of the controller. Do not use wood or tin screws but screw with bolts (bolt and counter bolt). Secure all screws with studded discs from unfastening and vibration. The length of thread has to be at least 1.5 x thread diameter, otherwise use thread bolts.

- the battery to be used is suitable and if it is connected correctly (check voltage)
- the maximum solar current of the solar generator does not exceed the connection the connection value of the controller.

Wiring

Solar modules produce current when light is falling in. Even at a small light in fall the total voltage is applied. Cover your solar modules against light and fix it with a tape. By this means the modules can be installed without voltage. The modules must not be short-circuited in order to ensure voltage-free operation. Do not shortcut the module controller terminals (M + / M -) when the battery is connected !



Only use well insulated tools!

Each blank wire end which is not connected immediately is to be insulated at once!

All works are to be done only on a dry underground! Components (modules, cables etc.) may not get wet.

Pay attention to the right polarity!

Hints: A grounding of the components in standalone systems is not necessary, not useful or can be prohibited by national regulations (e.g., DIN 57100 part 410 prohibition of the grounding of safety low voltage circuits). Further hints see point 10.

Confectioning:

- On principle connect all cables before connecting them.
- Cutting to length.
- Insulating both ends and fixing multicore cable ends.
- covering of blank wire ends with insulating tape.

• Mark every wire end

Battery Cable : A+, A-
Module Cable : M+, M-
User Cable : L+, L-

Connect module and phase wires in the sockets of the PV modules only according to the instructions of the manufacturers.

In order to rule out any failure the system components have to be wired in following order.

1.Battery, 2.Module, 3.User

Connection of the battery with the controller

- Remove fuse from the controller.
- Lay Accu cable (A+,A-) between controller and battery parallel.
- Connect accu cable with connection

terminal of the controller, note correct polarity.

- Attach external (floating) fuse at the accu cable near the accu terminal:
 - 10 A controller 10A (color red)
 - 20 A controller 20A (color yellow)Do not insert fuse yet
- connect battery cable A+ with battery-plus pole.
- connect battery cable A- with battery-minus pole.

The external fuse is not included.

Connection of a solar generator with the Controller

- Connect module cable ends (M+, M-) with the controllers terminal, note correct polarity.
- Only connect solar generators as energy source (no wind generators or fuel engine).

Connection of the users

- Protect every user circuit by a fuse.
- Before connection of the user cable switch off all users (remove fuse), in order to avoid sparking.
- Connect user cable with the terminal of controller. Note correct polarity!

Users which shall not be disconnected by the load disconnect (e.g. emergency light, radio contact) may not be connected directly with the battery! Higher danger of overdischarge which is no longer controlled by the system controller! Protect these users by a separate fuse.

Secure cables with pull relief near the controller. Also attach pull reliefs at all other components.

Installation of the external temperature sensor

The optional temperature sensor consists of a ring cable terminal with 8 or 10 mm diameter and a 2-pole connection terminal. It is connected directly at or under the battery terminal. Now connect the sensor with a two pin terminal at the controller. See illustration 1+2. Remove resistor (33K Ω) when the temperature sensor is installed. It is necessary that the controller is operated either with temperature sensor or this resistor.

4. Operation

a. Putting system in operation

After wiring check the following points :

- right polarity at all connections (cable marking).
- tightness of cable connections
- proper function of all pull reliefs.
- parallel laying of accu cable,
- tightness of screws and terminal connection (especially for use in cars).
- Insert fuses in the controller and battery, than wait until the upper LED flashes green (after 2 min. at the latest).
- Remove the cover of the solar generator. The battery voltage may be, even for a new and well-charged battery , below the reconnection voltage of 12.6 V. The lower LED at the controller shows when the controller is taken into operation. The battery has first been charged for a while before the users are cut off by the controller.
- Wait until the solar generator is charged and the red LED goes out. Check the charge current during this process.
- Charge the battery with external charger (only if necessary). The same status can also arise after changing the battery. Should no charge current flow, the generator connection cable can be at the wrong polarity.
- Users can now be operated.

b. Status Displays

State of Charge (SOC) Display

The state of charge of the battery is indicated by the upper LED which changes its colour in 10 levels from red (apprx. 0% SOC) via yellow (apprx. 50%) to green (100%).

Overdischarge prewarning

When the SOC is lower than 40% the user is warned of a load disconnection by a fast flashing of the lower LED (10x faster than the upper LED).

Overdischarge protection

A disconnection of the load by the overdischarge protection is shown by a slow flashing of the right LED. The load is disconnected when the SOC is 30% (red/yellow color display). The load is automatically reconnected when the SOC is 50% (yellow color display). The SOC can also be determined during the flashing by the color of the LED.

Information Display

The information display is flashing green during normal operation. As soon as a red colour tone can be seen there is an error. Table 2 shows which kind of error.

c. Maintenance

The controller is maintenance free. The complete PV system is to be checked at least once a year according to the specifications of the manufacturer. When it is used in vehicles the screws are to be tightened in short intervals. Check if pull-reliefs and cable connections are tight, screws are to be fastened up if necessary. Any dust or dirt is to be removed from the housing. Ventilation is to be ensured.

5. Errors

The controller is protected from destruction by various measures. Nevertheless see that it is operated properly. Part of the errors is indicated by means of the Info LED. Only this errors can be shown which occur when the controller is correctly installed. Should other errors than described arise, please check first

if the controller is connected with accu, module and users (load) at the correct polarity. Then check if the fuse is defect. In case of an error, the controller automatically switches off the load

6. Safety Precautions, Nonliability, Guarantee

General Safety Precautions

For your own safety following points are to be noted :



When wiring the controller do not reduce architectural measures for fire prevention. For details see "System

Wiring".

Do not install or operate PV-components in rooms, in which easy flammable gas mixtures can develop e.g. from gas cylinders, paints, lacquers, solvents!

Do not store these substances in rooms where PV-components are installed!

Avoid sparkings!

Solar modules produce current when light is falling in. Even at a small light infall the full voltage is applied. Therefore work carefully and pay attention to the corresponding safety precautions.

During assembly and installation in a direct current circuit of a PV-system voltages up to 50 V can arise.

Therefore: Do not touch blank wire ends!

Only use well insulated tools!

Do not use measuring equipment of which you know that it is damaged or defect!

The constructive safety precautions of the

charge controller can be negatively be affected when it is operated in a way not specified by the manufacturer.

Any labels attached by the manufacturer may not be removed or made unrecognizable.

A restriction of the ventilation can lead to an overheating of the controller and thus to a failure. Do not cover ventilating slots and cooling ribs.

All works are to be executed in accordance with national and local regulations!

For an installation abroad the corresponding authorities are to be consulted.

Keep your children away from your PV-System!

How to use this manual

This manual describes the functions and installation of a solar charge controller in a PV-system with a battery as storage. For installation of other components e. g. solar modules and battery, please see the corresponding manual of the manufacturers. Make sure that all preparatory measures are taken. Only start to instal your controller

when you are sure that you have understood this manual. Only proceed in the order stated in this manual.

This manual has to be made accessible for third persons for all works done at the PV-system and has to be passed over when it is sold.

Nonliability

The producer cannot survey the observation of this manual as well as the conditions and methods for installation, operation, use and maintenance of the system controller. Improper installation can lead to material damage and thus can endanger persons. Therefore we do not take any liability and responsibility for losses, damages and costs which are due to an improper installation,

operation, use and maintenance or any other consequences. Furthermore we do not take any liability for infringements of patent rights, or rights of third persons, which result from the use of this system controller. The manufacturer reserves the right to make alterations without prior notice concerning the product itself, technical data or the installation and instruction manual.

Guarantee

The manufacturer repairs all manufacturing and material defects which show in the system controller during the period of warranty and which are limiting the functions of the controller. Natural signs of wear are no defects. There is no guarantee when the defect was caused by end users or third persons, especially by improper installation or operation, incorrect or careless handling, excessive use, poor structural work, unsuitable ground or inappropriate operation or use. There is only guarantee when the defect was immediately after discovery claimed by your dealer. The claim has to be addressed via your dealer. A copy of the receipt has to be enclosed.

A detailed description is necessary for a quick handling. After a period of 2 years after the purchase contract by the end user, there are no guarantee claims possible with the

exception that the manufacturer agrees to a longer period specifically and in writing. The guarantee of the retailer, owing to the sales contract with the end user is not touched by this guarantee. Guarantee can be in the form of repairing or substitution. The cost for exchanging, sending or reinstallation are not included. Should repairing or substitution not be possible or are not within suitable time despite additional time by the customer, the deduction in value, caused by the defect is substituted or, when this is not enough for the end user, the contract will be annulled.

Further claims against the manufacturer owing to this guarantee declaration, especially claims for damages because of bwer profit, damages for loss of use as well as indirect damages are excluded as far as there is no necessity of legal liability.

7. Technical Data

Solar Charge Controller		ST10	ST20
System Voltage		12 / 24V	12 / 24V
Admissible Ambient Temperature		-25...+50°C	-25...+50°C
Admissible humidity		75%	75%
Max. Module Current I_K		10A	20A
Max. Load Current I_L		10A	20A
Sum of Currents (I_K+I_L) at $T_a = 30^\circ\text{C}$		20A	40A
Sum of Currents (I_K+I_L) at $T_a = 40^\circ\text{C}$		18A	36A
Sum of Currents (I_K+I_L) at $T_a = 50^\circ\text{C}$		16A	32A
Protection		IP65	IP65
Connection terminals (fine / single wire)		4 / 6 mm ²	10 / 16 mm ²
Cable Glands (Inner Diameter)		3x PG16, 1x PG9 14mm bzw. 8mm	3x M25x1, 1x PG9 17mm bzw. 8mm
Weight		400g	600g
Dimensions		160x57x112mm	175x58x117mm
AtonIC [®]			
Regulating specifications dependent from:		SOC	tension
Disconnection of User		< 30%	< 11,1 V
Prewarning of Load disconnection		< 40%	< 11,7 V
Reconnection of User		> 50%	> 12,6 V
Final Voltage Normal Charge	13,7 V		
Final Voltage Cycle Charge	14,4 V	bei SOC < 70%	Ubatt. < 12,4 V
Final Voltage Equalization Charge	14,7 V	bei SOC < 40%	Ubatt. < 11,7 V
Temperature Tracking of Final Voltage		-4mV/K/cell (with ext. Sensor only)	

Table 1, voltage have to be doubled for use in 24V systems.

a. Block Diagram

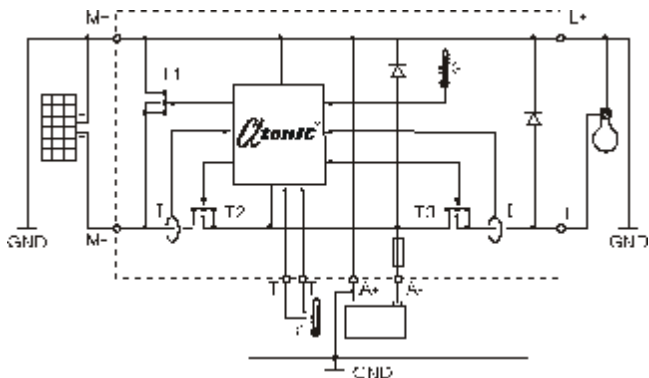

Figure 1, positive ground

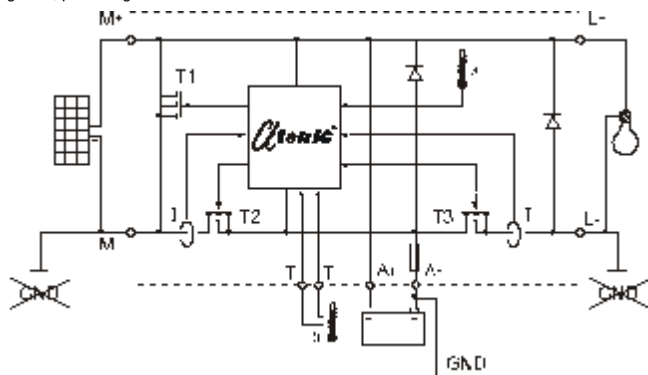

Figure 2, negative ground

Following passages describe only the technical possibilities of a grounding. Aim is to maintain the controller's functions. National regulations of the operational area are to be adhered to by the electrician to do the installing. Loss of the safety low voltage status arising from grounding has to be compensated by corresponding insulation methods of active parts (protection against direct contact). When a grounding at the plus-side is chosen, it can also be taken as common mass for all system components. All plus connections are internally connected anyway. See figure 1.

Only one minus connection of the components module, accu and load can be grounded. When your solar system determines a minus mass (e. g. accu minus) only this component can be connected with this mass. A connection with further minus poles (module or load) bridges control elements and the fuse. This can lead to a malfunction and destruction of the controller. In systems with determined load-minus-mass (e. g. grounding of aerials), all further components have to be connected floatingly. See figure 2.

b. Groups of solarpanels

- You can raise the possible solar module current by establishing several groups of modules. Each group will be controlled by a separate charge controller. One battery can be charged by more than one controller but you must not connect the bad-outputs of the charge controllers ! If you do not need

- the deep discharge protection for the battery the load can be connected directly to the battery.
- Do not connect several different batteries to each other (parallel). This can be harmful to the weakest battery.

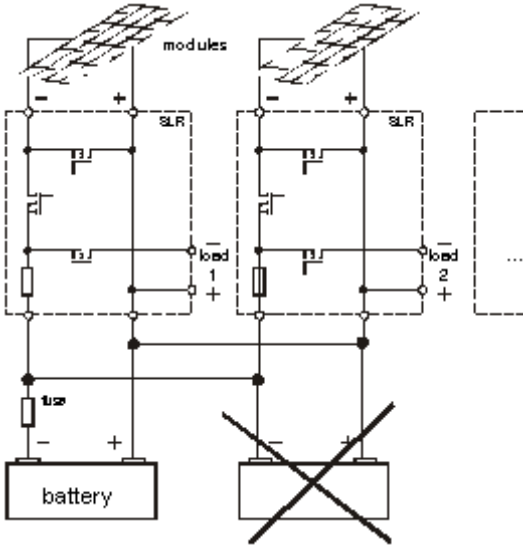

Grouping of solarpanels

c. Information display

	Information LED	Information Display	Protective measure of controller	Reset
Normal operation	green flashing	revolving values	-	-
Overcurrent Load > 110%	red -green flashing	load current	load is disconnected	switch off or disconnect all users ¹⁾ , remove error, switch on again
Overcurrent Module > 110%	red yellow flashing	module current	load is disconnected	automatically, when overcurrent does no longer exist 1)
Overtemperature > 85°C	red constant light	over temperature	load is disconnected	automatically, when temp. has decreased 2)
Overvoltage battery > 15 / 30V	yellow flashing	over voltage	load is disconnected module short circuited	automatically, when Voltage has increased 3)
Undervoltage battery < 11/22 V	red flashing	low voltage	load is disconnected	automatically, when Voltage has decreased again

d. State of Charge display

SOC %	tension V	SOC-LED display	measures of the controller
100	13.7	green	-
50	>12,6	yellow	load reconnection
<40	<11,7	red-yellow fast blinking	prewarning battery empty
<30	<11,1	fast red blinking	load disconnection
0	<<11,1	red blinking	load disconnected